



## Design and Implementation of a Smart Safety System for Rental Cars Using IoT and E-Commerce Mobile App Integration for IIUM Community

Muhammad Zaid Hazim Johari<sup>1</sup>, Mohamad Amir Syakirin Shafie<sup>1</sup>, Ahmad Anwar Zainuddin\*<sup>1</sup>, Abu Ubaidah Shamsudin<sup>2</sup>, Ammar Haziq Annas<sup>1</sup>, Mohamad Syafiq Asyraf Bharudin<sup>1</sup>, Mohamad Nur Badri Mahazir<sup>3</sup>, Alin Nur Maisarah Ahmad Razmi<sup>3</sup>, Nur Anis Sofea Kamarul Zaman<sup>3</sup>, Nur Adlin Muhammad Zahid<sup>3</sup>

<sup>1</sup>Dept. of Computer Science, Kuliyyah of Information Communication Technology, Islamic International University Malaysia, Gombak, Selangor, Malaysia

<sup>2</sup>Jabatan Kejuruteraan Elektronik, Fakulti Kejuruteraan Elektrik dan Elektronik, Universiti Tun Hussein Onn, Batu Pahat, Johor, Malaysia

<sup>3</sup>Dept. of Information Systems, Kuliyyah of Information Communication Technology, Islamic International University Malaysia, Gombak, Selangor, Malaysia.

### KEYWORDS

IoT smart accident detection  
Mobile Application  
GSM Module  
Proteus 8

### ARTICLE HISTORY

Received 9 April 2023  
Received in revised form  
10 June 2023  
Accepted 2 June 2023  
Available online 3 June 2023

### ABSTRACT

Traditional car rental systems are cumbersome for both consumers and rental companies due to the manual and time-consuming nature of the process. This work proposes the integration of a car rental system using mobile app administration and IoT (accident detection system) to address this issue. The system consists of an e-commerce platform and an IoT-powered Accident Detection System. The e-commerce platform enables users to rent automobiles and make payments online, while the Accident Detection System assists car owners in identifying any incidents involving rented vehicles. A Google survey conducted among the IIUM community (consisting primarily of students and staff) revealed that 96% of users and 100% of vehicle owners are in favour of a mobile application for car rentals and the installation of an accident detection system in rental cars. Through simulation, seat belt detection and accident detection have been developed, and future include implementing real-time monitoring using IoT technology to monitor rental compliance, locate vehicles requiring maintenance, and locate stolen vehicles. The proposed system has the potential to make automobile rental services more convenient and secure.

© 2023 The Authors. Published by Penteract Technology.

This is an open access article under the CC BY-NC 4.0 license (<https://creativecommons.org/licenses/by-nc/4.0/>).

## 1. INTRODUCTION

The integration of e-commerce and internet of things (IoT) technology into an online car rental platform is a modern solution that provides convenient rental services for customers and efficient fleet management for car rental companies. This system improves the traditional car rental process by making it effortless and efficient for both parties [1]. By leveraging e-commerce, customers can search for and reserve rental automobiles without visiting a physical location and complete the rental process electronically. This eliminates the need for manual documentation and makes the experience more convenient. The incorporation of IoT technology enables the

tracking and monitoring of rental vehicles in real time, allowing rental companies to efficiently manage and maintain their fleets. This may result in operational enhancements and improved customer experiences [2]. Adoption of an e-commerce and IoT-based vehicle rental system is anticipated to offer significant benefits for both customers and rental companies, including enhanced convenience, efficiency, and usability. The graphical abstract presented in Figure 1 provides an overview of the challenges and opportunities associated with the implementation of IoT-based smart safety systems for car rentals, specifically in the context of a case study focused on the IIUM community.

\*Corresponding author:

E-mail address: Ahmad Anwar Zainuddin <[anwarzain@iium.edu.my](mailto:anwarzain@iium.edu.my)>.

<https://doi.org/10.56532/mjsat.v3i2.156>

2785-8901/ © 2023 The Authors. Published by Penteract Technology.

This is an open access article under the CC BY-NC 4.0 license (<https://creativecommons.org/licenses/by-nc/4.0/>).

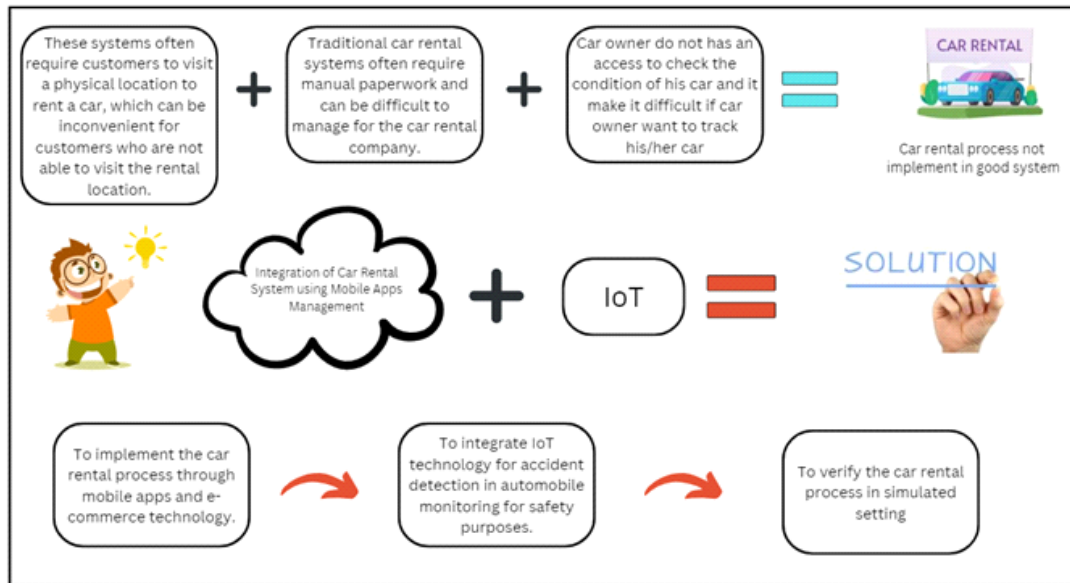

**Fig. 1.** Challenges and Opportunities in Implementing IoT-based Smart Safety Systems for Car Rentals

The structure of this article consists of five sections. In Section 1, the introduction to the project is addressed, including a discussion of car rental system activities, E-commerce, IoT, and the overall development of the project. Car rental management system, accident detection system, internet of things (IoT) components, and m-commerce are outlined in Section 2 of this paper's literature review. The methodology that will be used for this project is described in Section 3, which includes information about the dataset and the flowchart for the work. Section 4 discusses the proposed system implementation, which will include mobile applications and Proteus 8 Design Suite simulation of the system prototype. This section also contains a description of the simulation results and a discussion of the smart safety system for rental vehicles using IoT and mobile app integration for IIUM community. Section 5 concludes the article by discussing the significance of this system's advancements on intelligent activities.

## 2. LITERATURE REVIEW

In this section, a summary of the literature review for this work is presented. all the previous works related to the smart safety system for rental cars are listed in Table 1.

### a. Car Rental Management System

The automobile management system consists of multiple modules. There modules are administrators and end users, facilitating vehicle reservations, streamlined customer request management, and exhaustive examination of available cars, including transaction verification and inventory display, with clear identification of unavailable or limited stock.

### b. Accident Detection System

The study in [3] describes the Smart Car accident detection system, which employs Internet of Things (IoT) technology to identify and respond to accidents in real time. This system is intended to be put in a vehicle and makes use of sensors such as accelerometers and gyroscopes to monitor the vehicle's

motions and identify any rapid changes that may signal an accident. In addition to detecting accidents, the Smart Car system can monitor the car's movements in real time and alert the driver to possible risks or unsafe driving habits. This can include warnings for excessive speeding, abrupt braking, or swerving. The system's goal in sending these notifications is to increase overall driving safety and minimize the number of accidents on the road.

### c. Internet of Things (IoT)

IoT allows internet-connected devices and sensors. This allows novel ways to problem-solving and life improvement. Smart gadgets and internet access enable electronic devices to communicate, share data, and function together. The IoT can help many economic, governmental, and public or private sectors achieve their goals. IoT has accumulated a great deal of importance and evolved into a fundamental aspect of our daily lives, including everything from connected homes and wearables to industrial automation and transportation. This innovation entails the development of a complex network composed of interconnected devices, frameworks, intelligent systems, and sensors. These components collaborate to deliver an unprecedented level of ease and automation [4].

### d. Raspberry Pi

The purpose of incorporating a Raspberry Pi into an accident detection system is to produce a tiny, and portable device capable of monitoring and detecting accidents in real time. In the study conducted by [5], the raspberry pi is employed as the system's main processing unit. It is connected to sensors that detect unexpected movements or impacts and is linked to a GPS module that provides position information. The Raspberry Pi receives data from the sensors and processes it in real-time to determine if an accident has occurred.

**Table 1.** Summary of the literature review

Ref.	Research Design/Variables Studied	Equipment/Apparatus	Important findings	Limitations of study	Research gap
M. G. Albino and V. Acebedo (2021) [14]	The effectiveness and acceptance of the produced application by the respondents will be evaluated based on a survey performed by the researchers.	Survey questionnaire	Customers may book cars using the auto management system that incorporates a scheduling algorithm, and the company can quickly plan and handle consumer requests.  The program also allows users to examine the vehicles that are currently available at a car rental agency. It contains a transaction page where the system administrator may quickly verify the automobile's availability and other data required by the car rental company.	Number of survey respondents	Identified a method:  Allocate more time to find more respondents
E. Turban et al. (2017) [12]	Implementation of IoT and m-Commerce in car rental industry	- Hertz mobile applications  - NeverLost GPS Navigation System	The Hertz scenario highlights many mobile transportation solutions that can assist enhance both customer service and corporate operations. The programs are run on mobile devices and are connected to the internet through a wireless network.  The Hertz NeverLost GPS technology, which has a display screen and audio instructions, is included in many of their vehicles. The routes and business details, including the locations of the closest hospitals, petrol stations, and restaurants, are presented on a map.	One of the main concerns with the usage of mobile computing technologies, particularly LBS, tracking, RFID, and context-aware apps, is the invasion of privacy.	Identified a method:  Increase the security of the apps and IoT devices so users' data is safer.
K. Shaukat et al. (2021) [13]	Commercial IoT systems and gadgets go beyond PCs, tablets, and smartphones. These can include coffee makers, washing machines, headphones, wearables, and lamps. Integrating common things into a network of connected devices and systems can streamline procedures and boost industry productivity. IoT technology helps businesses obtain insights into their operations and make data-driven decisions to improve procedures and customer experience.	Commercial Internet of Things systems and devices can take the form of virtually anything imaginable, including cell phones, coffee makers, washing machines, headphones, lamps, and wearable gadgets, amongst other things.	IoT device assaults have occurred, according to CISOMAG, and they have created a list of their top 10 cases to show that all the gadgets that are used virtually every day are not as safe as one may anticipate.  IoT systems frequently have parts of them, or at least some of them, in locations that are open to the public. In light of the possibility that many of the system's members may be compromised, the entire system has to be secured.	A Gartner prediction supports this assertion: IoT will be involved in over 25% of known attacks against businesses by 2020, although accounting for less than 10% of IT security spending.	Identified a method:  Increase the budget on IoT security

Ref.	Research Design/Variables Studied	Equipment/Apparatus	Important findings	Limitations of study	Research gap
F. Y. H. Ahmed et al. (2021) [1]	Assess and contrast the issues with the search engine's general automobile rental system to determine the worth of the rental car	- EZGO website and application - Survey questionnaire	The EZGO smartphone app has shown that it will improve the current vehicle rental system. The purpose of this is to offer a platform where visitors to Malaysia may rent a wide range of automobiles at varied costs as well as easily and quickly anywhere in the nation.  It is determined that the suggested approach has addressed the client's car rental needs.	Type of vehicles and area of coverage	Identified method:  Promote the app to get more users to rent out their vehicles
S. Sakarin and G. Phanomchoeng (2021) [11]	Track car location and some statuses of car which are fuel level, vehicle's speed, engine rpm and odometer of cars	- Cobox connected to OBD-II port	Knowing more about their vehicles may be quite useful for maintenance and telematics in the setting of a car rental firm.	One of the main concerns with the usage of mobile computing technologies, particularly LBS, tracking, RFID, and context-aware apps, is the invasion of privacy.	Identified a method:  Increase the security of the apps and IoT devices so users' data is safer.
M. K. Priyan and G. U. Devi (2019) [10]	Modern IoT, IoV, and IoE systems face a number of difficulties and problems. Security concerns and many IoT applications in healthcare	NA	IoV is used to connect objects, vehicles, and surroundings so that data and information may be sent between networks. The primary purpose of IoV is to create a human-vehicle-thing-environment that includes numerous objects, vehicles, and networks.	In the IoV system, cars may generally interact with one another, but there is a problem with how the content is distributed among the different vehicles	Identified method:  To distribute the material across multiple vehicles in the IoV system, a cloud-based Bayesian coalition game (BCG) based on Markov decision process (MDP) was identified.
A. Thakur (2021) [9]	Automating an efficient vehicle rental system	- XAMPP - Sublime Text - Web Browser - GitHub	When someone doesn't have their own car, renting one makes it easier for them to get around. This technique facilitates personnel and vehicle management while increasing client retention.  Online automobile reservations and delivery are now available for registered members. They can also pick up the rental car in person.	NA	NA
S. Kumar et al. (2019) [4]	IoT's various problems, particularly those related to its architecture and significant application fields.	NA	All the functionality of IoT systems are defined by the five key layers that make up the IoT architecture. These layers include the business layer, the network layer, the middleware layer, and the application layer.	Security risks and assaults.	Identified method:  Security procedures must be included into the IoT architecture at every layer.

#### e. GPS module

This system is designed to be highly effective in accident tracking using the Global Positioning System (GPS). The data collected can be utilized to determine the speed of the vehicle, which is an important factor in assessing the likelihood of accidents. The NEO 6M GPS module is incorporated in this system to monitor the location of the vehicle. This module has many advantages, including its compatibility with the Arduino module, ease of use, and quick response time, which allows for swift transmission of location information to a designated number for immediate assistance. The GPS module operates by utilizing three of the 27 satellites in orbit to track the vehicle's location [6]. With its sophisticated features and ability to accurately locate accidents, this device is a vital tool for emergency responders and those seeking to improve road safety.

#### f. GSM module

Global System for Mobile communication (GSM) modules are a type of electronic circuit that connects mobile devices to the GSM system. The modem, which is powered by the power supply circuit, is the most important component in this module, and it connects to the network to deliver messages. The GSM-based communication system is highly useful for transmitting information to the police station, hospitals, family members, and other parties [6]. This method has been used to communicate information on the Arduino board. To send and receive texts and make and receive audio calls to a specified person, the SIM900A GSM module is connected to the Arduino board. The module operates on a 3A power supply and uses Dual-Band 900 MHz and 1800 MHz frequencies.

#### g. Vibration sensor

The accelerometer or vibration sensor is an electromechanical tool used to measure acceleration, be it dynamic (caused by movement or vibration) or static (such as gravity's constant force). Essentially, the accelerometer serves as a transducer to detect acceleration and, hence, the movement of an object. This system uses the ADX1335 accelerometer, which is a three-axis accelerometer. The ADX1335 is a low-profile MEMS sensor constructed from micro-machined structures on a silicon wafer suspended by a poly-silicon spring. It relies on gravitational attraction to determine the object's position relative to the Earth. The accelerometer has three analogue pins, one for each axis, as well as two supply pins [3].

#### h. M-commerce

M-commerce is the practice of conducting e-commerce activities using mobile devices over wireless telecommunications networks. By leveraging the unique characteristics of mobile devices, such as ubiquity, convenience, interaction, personalization, and localization, m-commerce has the potential to enhance e-commerce and provide additional value to customers. The growth of m-commerce is driven by a variety of factors, including the increasing number of mobile device users, the rise of a "smartphone culture" among younger generations, customer demand for service-oriented experiences, vendor marketing efforts, falling device prices, a growing mobile workforce, improvements in performance-to-price ratios, and increasing bandwidth capabilities. As a result, m-commerce is becoming an increasingly important area of focus for businesses seeking to capitalize on the opportunities presented by the mobile revolution.

### 3. METHODOLOGY

#### 3.1 Flowchart for Integrated Mobile Application with Accident Detection System

Figure 2 shows the flowchart of mobile application for this work. This is a flowchart for mobile applications. When the application starts, the login divides into two users which are users who want to rent a car and car owners. For users who want to rent a car after they login, the system will bring them to the main page and users can search for the car they want and proceed with booking by paying online or choosing to pay with cash. For car owners, car owners can manage car availability by adding or removing the car in the list. Car owners can also check the payment made for booking. Next, for car owners, it has a special notification that will tell car owners what happened to their car.

#### 3.2 Use Case Diagram

Figure 3 showcases a use case diagram for this work. There are three actors which are user, car owner and system. The use case relates to users who register, login, search for a car for booking, book a car and make payment. The use cases relate to car owners which are to register, login, manage cars, manage payment and receive notification. The use cases relate to systems which send notification, detect car status, detect seatbelt status and display seatbelt status.

#### 3.3 Flowchart Accident Detection System (IoT)

Figure 4 shows how an accident detection system works by using Raspberry PI for this system. Car owners can view his/her car's condition through this system. In this system, there are two things: it will check which seatbelt is used or not and the LCD display will show the appropriate message according to whether the seatbelt is locked up or not. Secondly, this system has a vibration sensor that can detect whether someone is involved in an accident or not. If the car is involved in an accident, the system will use the GPS module and GSM module to send a notification to the car owner about the car location.

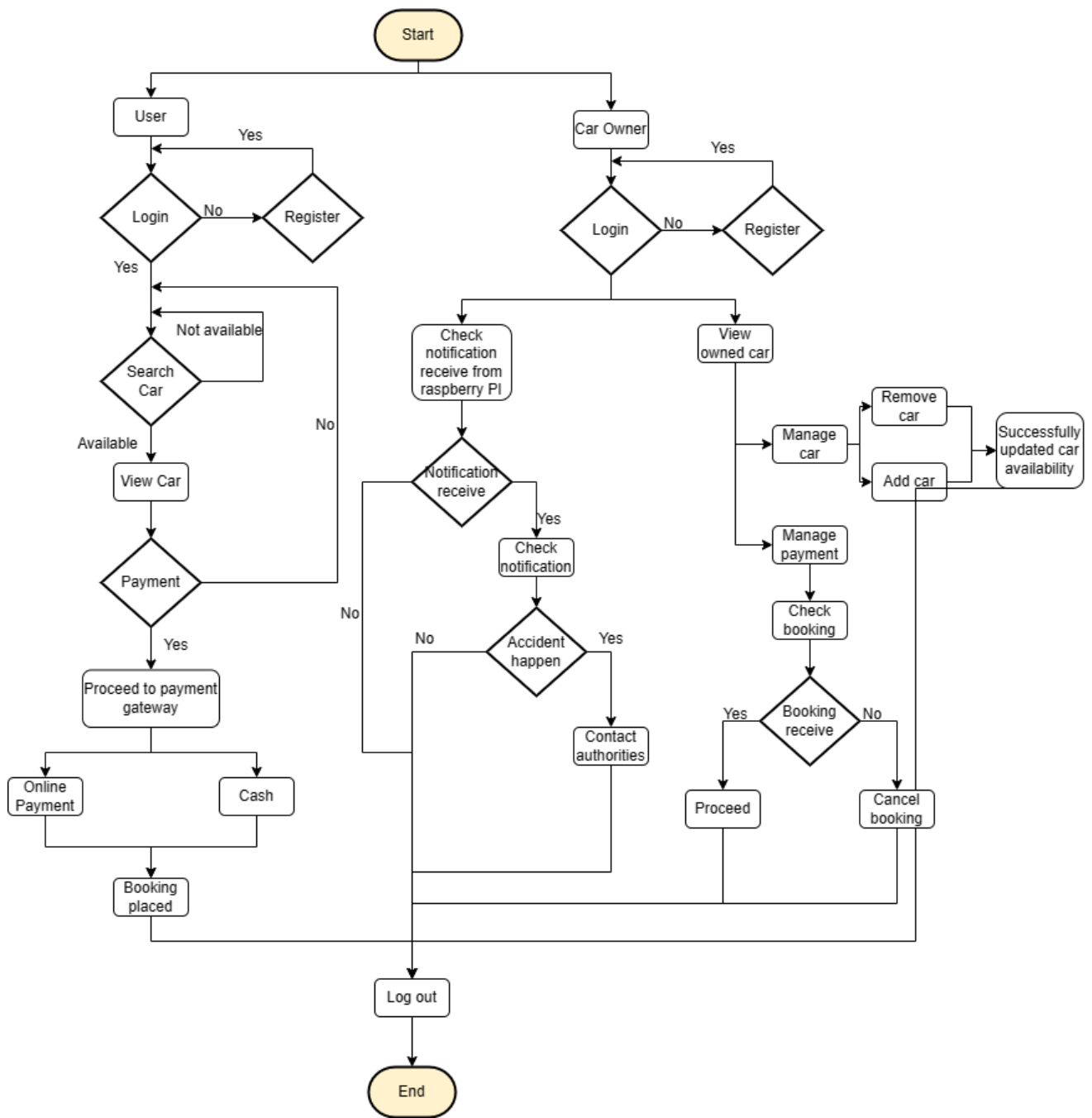

Fig. 2. Flowchart for Mobile Application

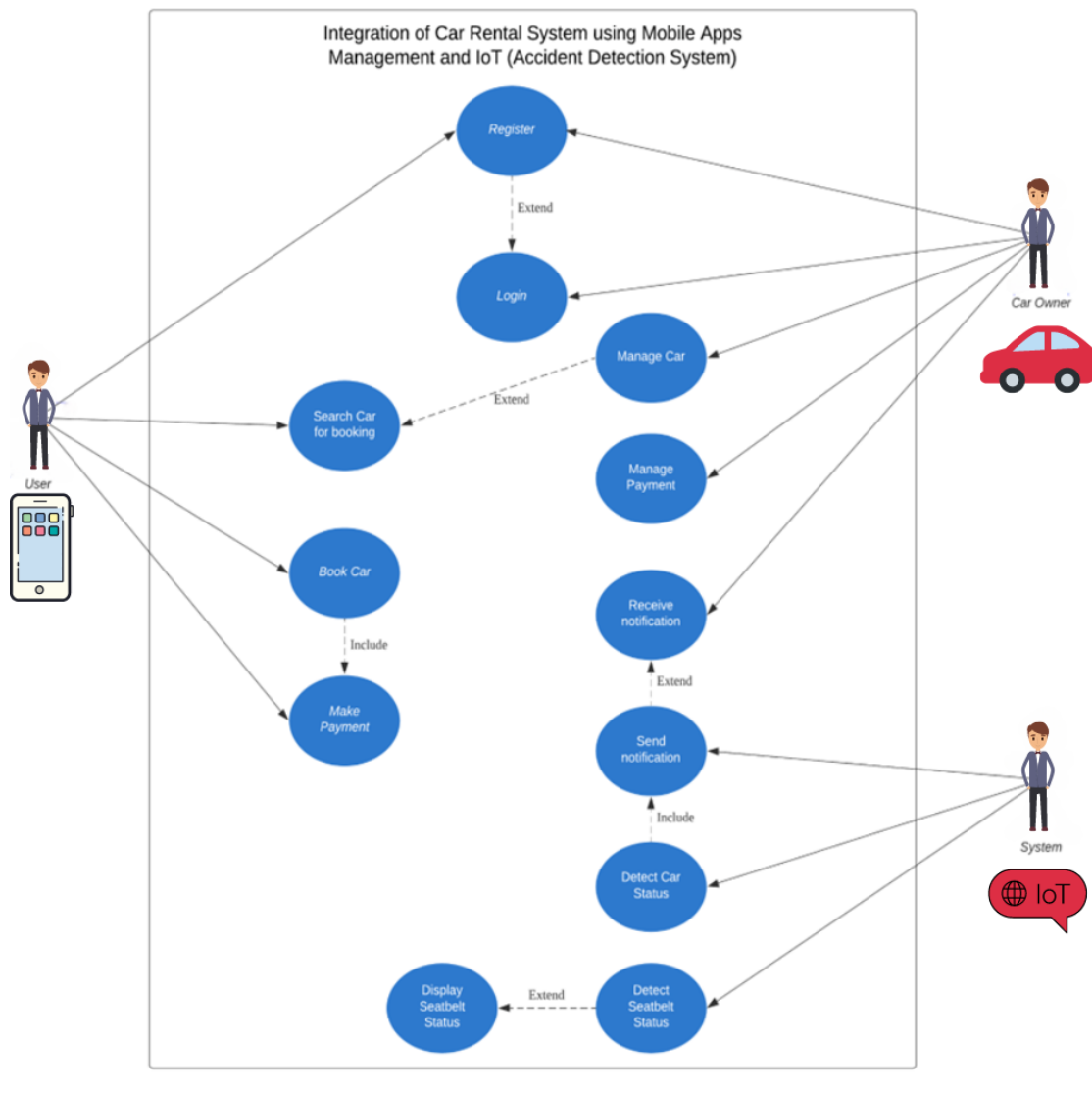

Fig. 3. Use Case Diagram

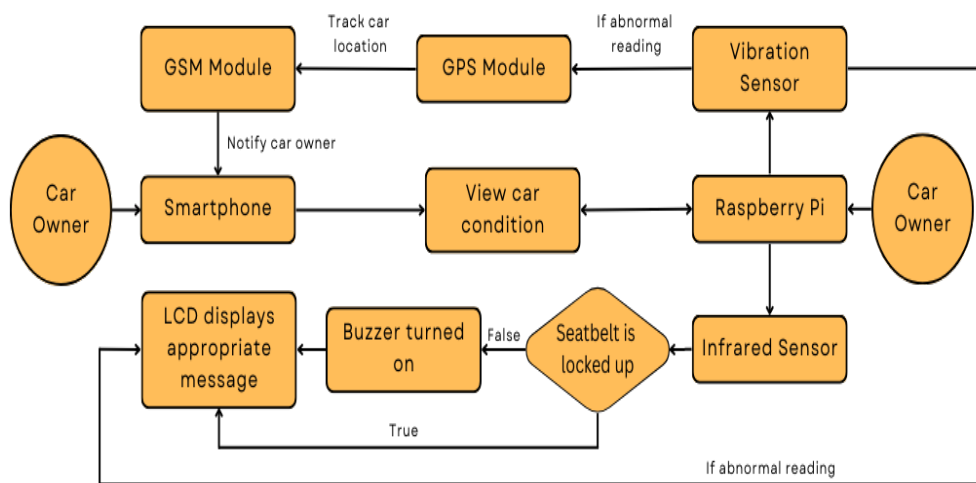
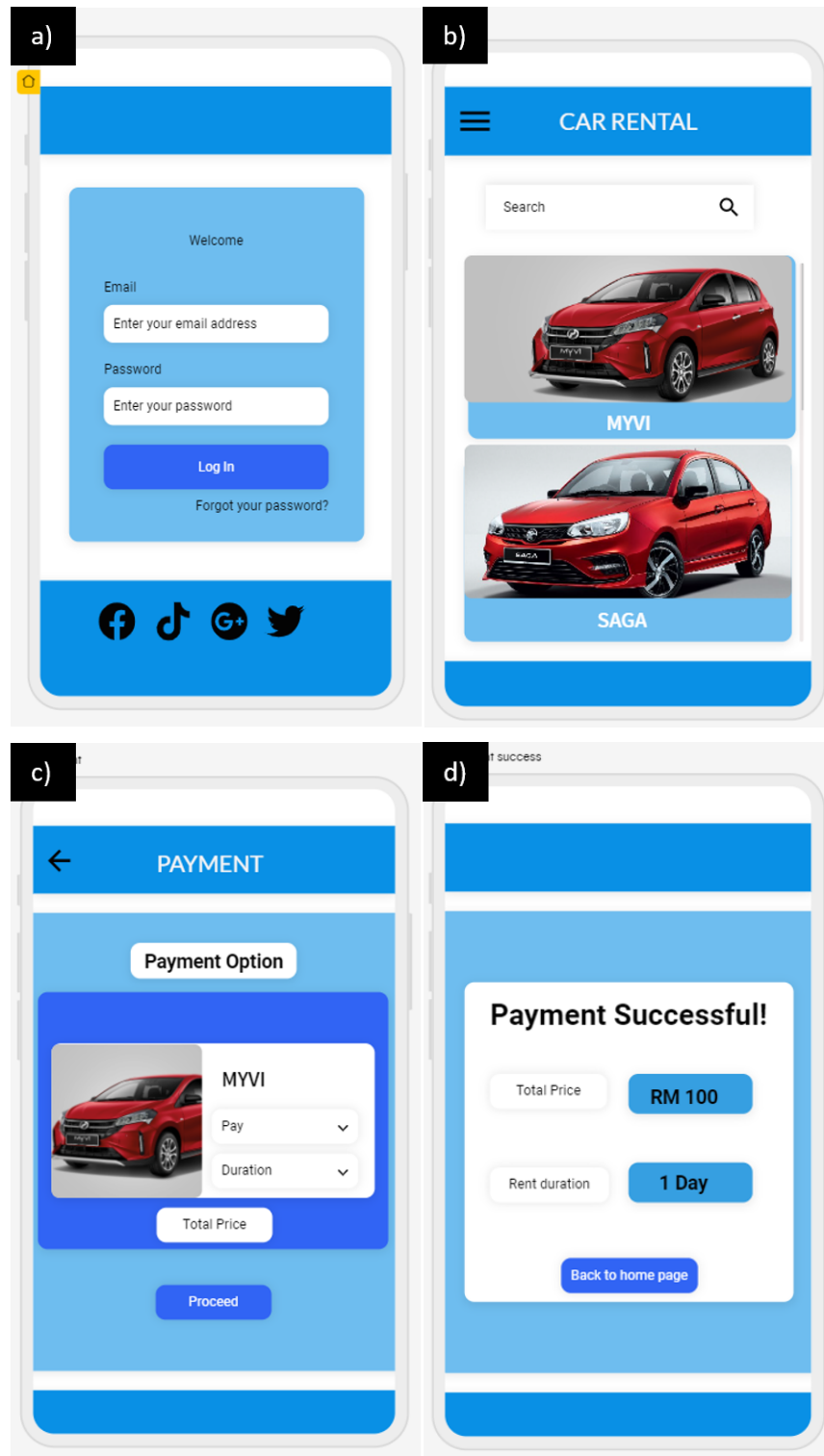

Fig. 4. Flowchart Accident Detection System (IoT)

#### 4. SYSTEM IMPLEMENTATION

##### 4.1 Mobile Application

Figure 5 presents an overview of the planned prototype for a mobile application-based E-Commerce car rental system.



**Fig. 5.** Mobile Application Prototype. a) Login interface. b) Car selection interface. c) Booking confirmation page. d) Successful booking page

4.2 Proteus 8

The Proteus 8 Design Suite, a software tool set mainly used for electrical design automation, was utilized to develop and test the system prototype. The program is commonly used by electronic design professionals and technicians to create schematics and electronic prints for printed circuit board fabrication.

In the event that it is determined that the user is not wearing their seatbelt, both the buzzer and the LCD display will sound to alert them to the problem. An electronic switch that is operated by an electrical signal is called a relay module, which brings us to our next point. In the event of an accident, the relay module of the accident detection system would function as a switch, reacting to a signal sent by the processing unit in order to take control of other safety-related equipment located within

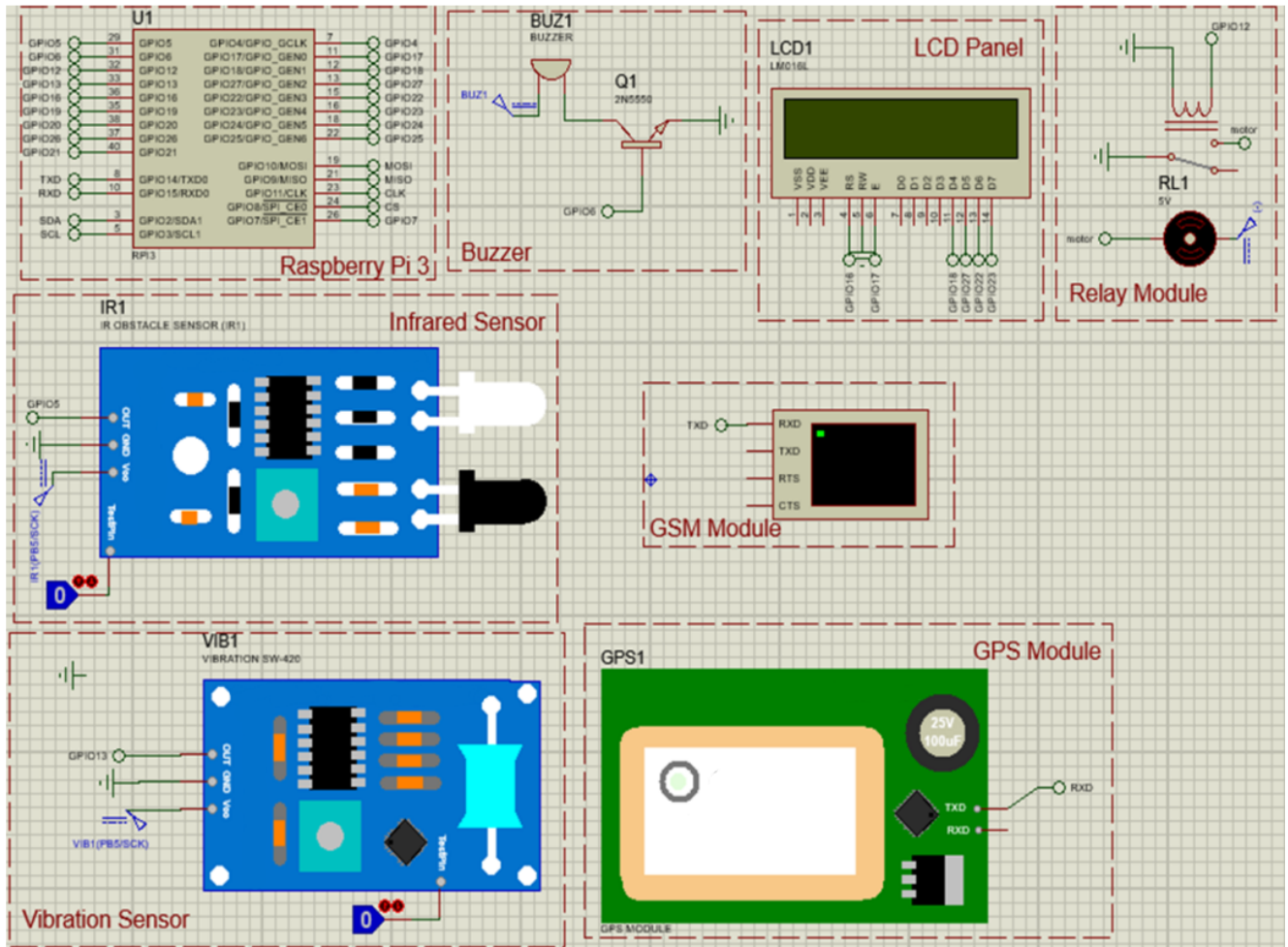

Fig. 6. Schematic Diagram of Accident Detection System

A high-level overview of a selected schematic diagram of an accident detection system is presented in Figure 6. A Raspberry Pi 3, a buzzer module, an LCD screen, a relay module, an infrared sensor, a vibration sensor, a GSM module, and a GPS module are some of the gadgets that are included in the system. The Raspberry Pi is utilised as the primary processing unit for the purpose of assessing whether an accident has taken place by collecting data from various sensors (such as accelerometers or GPS). The following step involves displaying information to the user via the LCD panel. This includes the message that greets you as you get in the automobile, the status of the seat belts, the condition of the car, and so on. Both the infrared sensor and the buzzer play a role in the process of determining whether or not the user has fastened their seat belt by determining whether or not the seat belt is present in the slot for the seat belt.

the vehicle. After that comes the vibration sensor, which is also called an accelerometer and is responsible for determining whether or not there have been any rapid shifts in motion or vibration. Next, the GPS module would be used to pinpoint the precise location of the car, and the GSM module would be used to send and receive data over a cellular network.

Both modules would be connected to the vehicle's onboard computer. The vibration sensor would detect the abrupt change in motion that would occur when an accident takes place and then send a signal to the Raspberry Pi. This signal would then trigger the appropriate actions, such as sending an alert to emergency services or automatically calling a predetermined contact. For the purpose of configuring the features of the system, the programming language python has been selected. The accident detection system (ADS) was simulated, and during the car's start-up, a welcome message will appear on the LCD panel for the user's benefit as shown in Figure 7. All of

the simulations that were developed based on this work are shown in Figures 7 through 17.

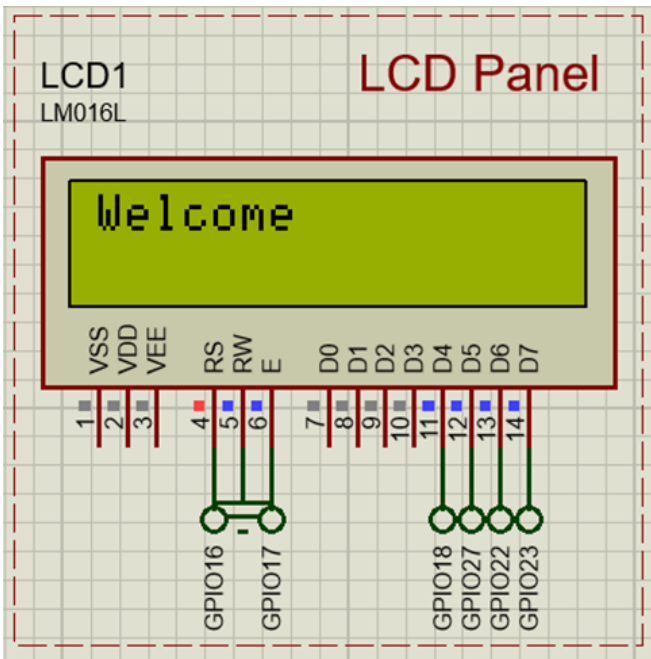

Fig. 7. Welcome message

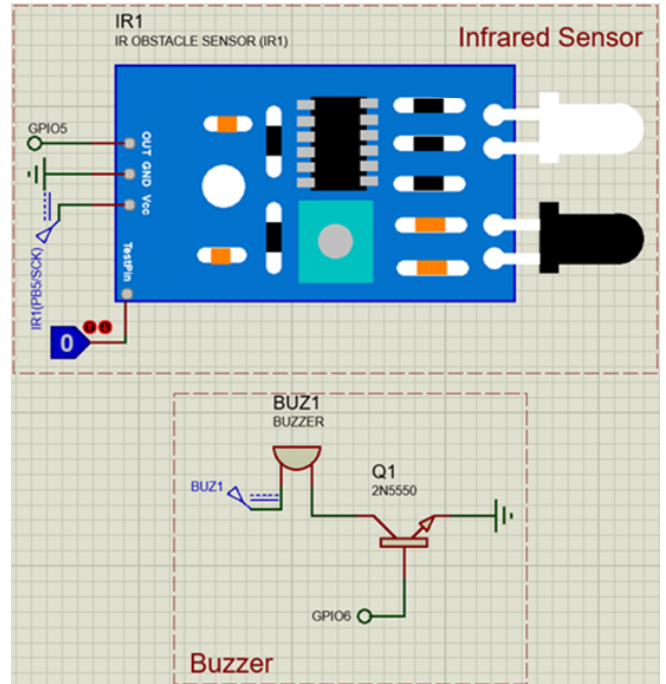

Fig. 9. Seatbelt detection module

LCD will prompt no seat belt detected.

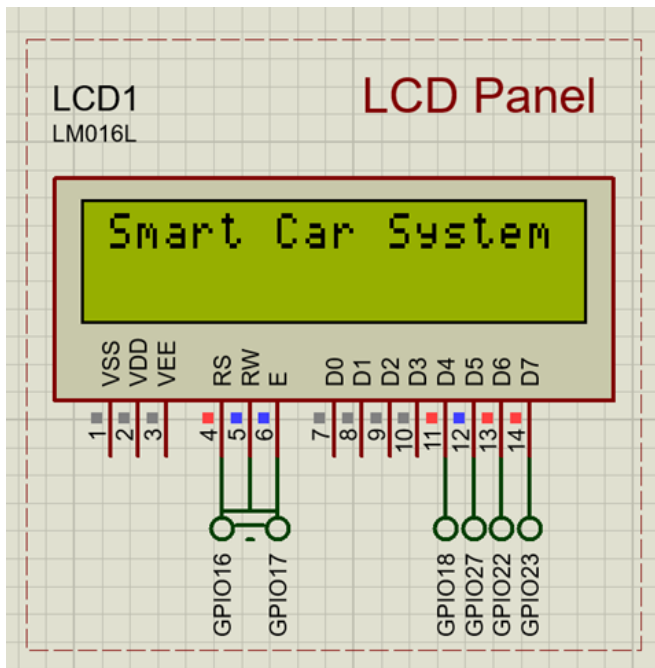

Fig. 8. Welcome message 2

As the vehicle starts, the infrared (IR) sensor will check for the presence of the seatbelt in the buckle. If no seat belt is detected, the IR sensor will give a 0 input and the buzzer will start ringing.

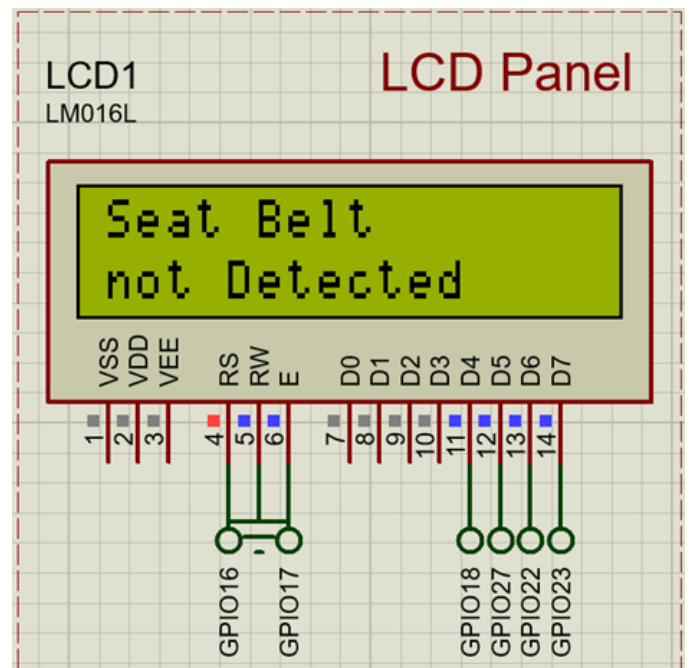

Fig. 10. LCD display for no seatbelt detected

Once the seat belt is inserted, input 1 is given, the car is now drivable (motor will start running).

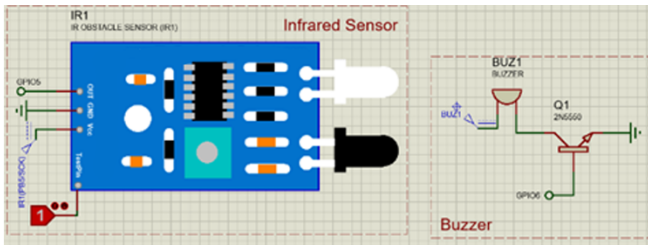

Fig. 11. Seatbelt inserted into buckle

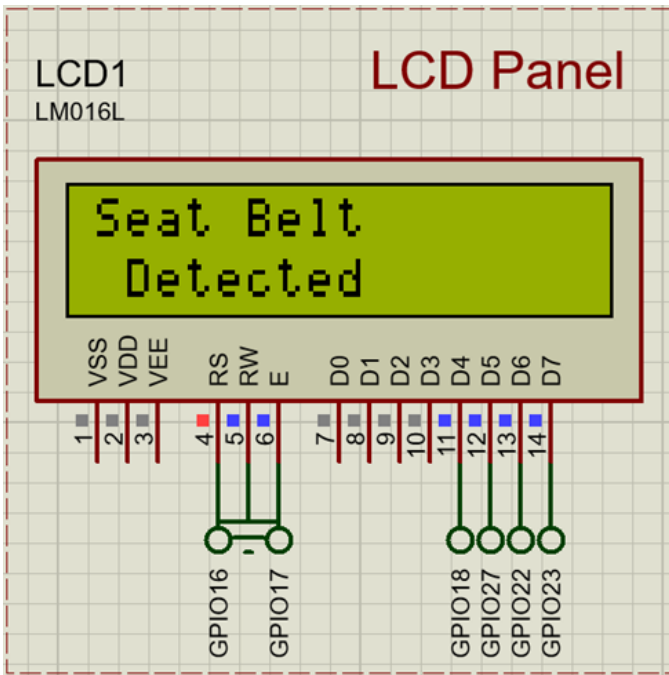

Fig. 12. LCD message after seatbelt is inserted

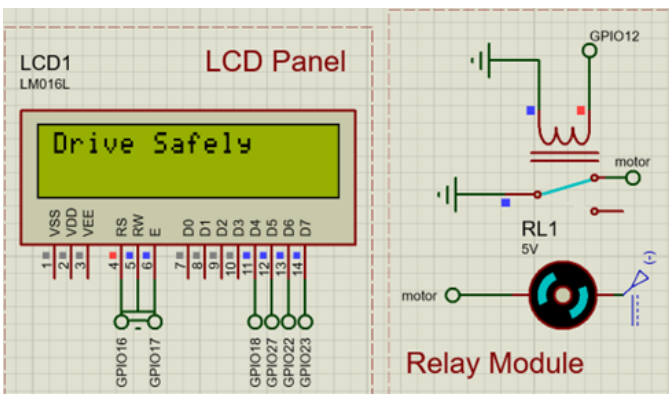

Fig. 13. LCD message and motor start

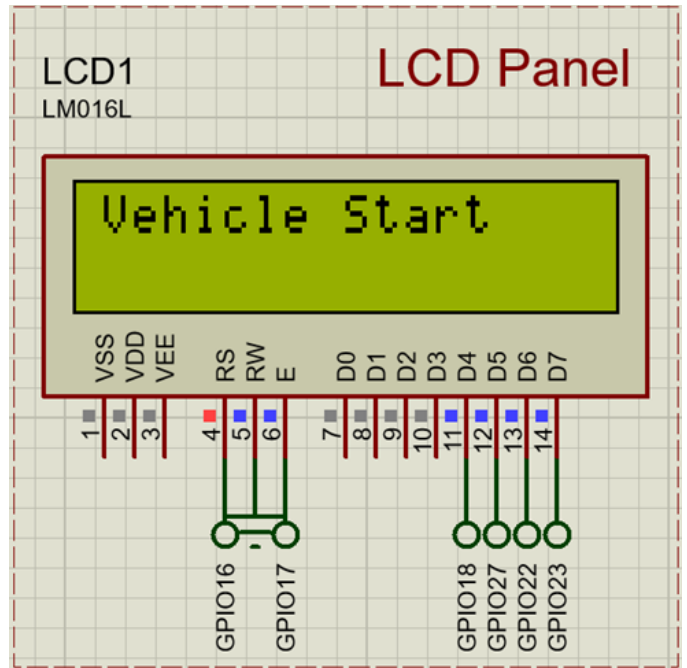

Fig. 14. LCD message

When an accident occurred (vibration sensor will give input 1). In the event of an accident, it is essential to have a reliable system in place that can detect the event and respond in a timely manner. Using a vibration sensor that is able to determine the force of the collision and initiate the proper response is one method that can be utilised to accomplish this goal. The driver, the automobile rental company, and the emergency services can all be notified of the occurrence automatically by the system if it has been designed to do so. This makes it possible to respond to the accident in a timely and effective manner, which could help save lives and reduce the amount of damage to property.

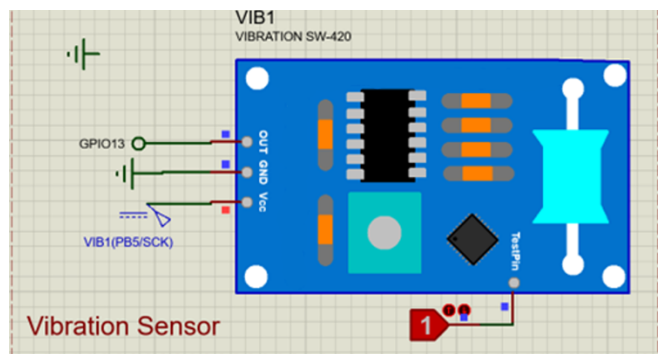

Fig. 15. Vibration sensor detects an accident

The LCD panel will prompt a message indicating an accident has occurred.

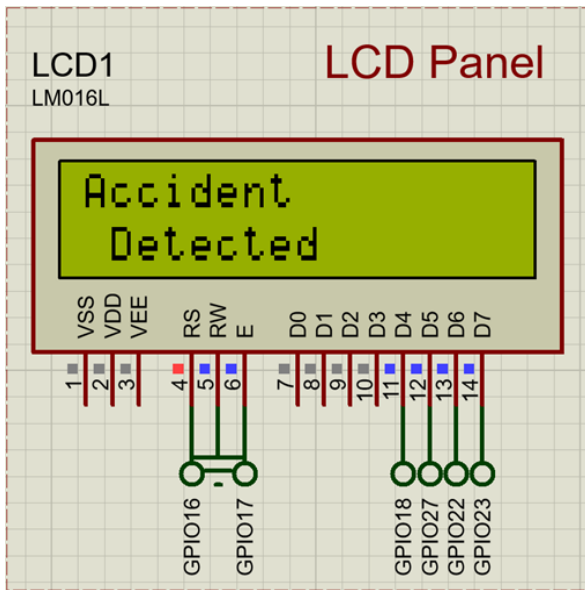

Fig. 16. LCD message when an accident occurs

A virtual terminal will simulate the action of contacting predetermined contact information and reports the location of where the accident happened.

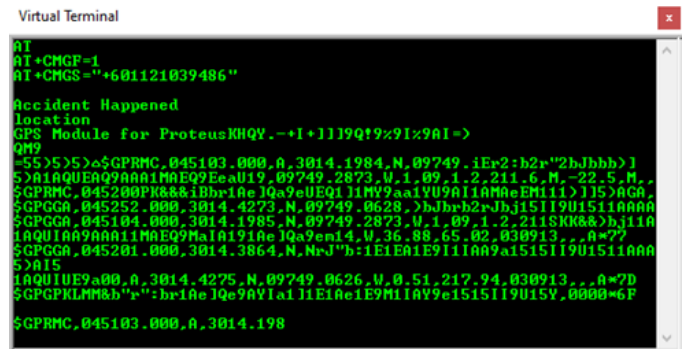

Fig. 17. Virtual Terminal reporting the accident

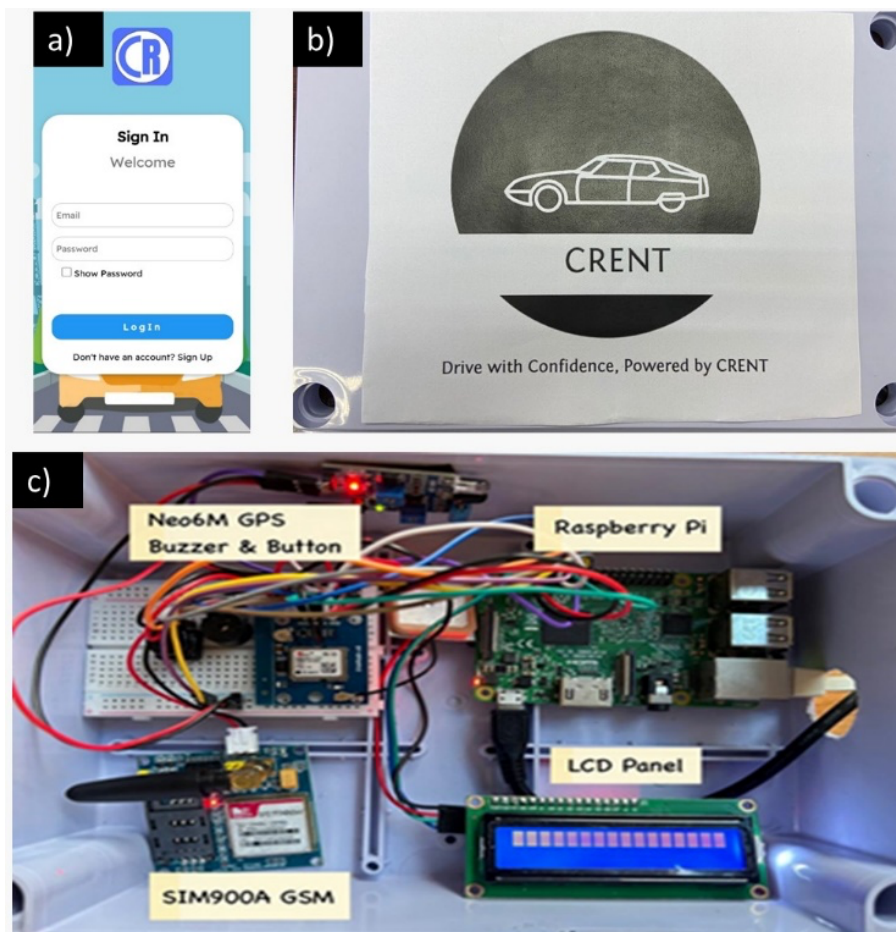

Fig. 18. Development of prototype. a) Mobile Application b) Top Cover Packaging Box. c) Hardware of IoT Module the Packaging Box

Figure 18 indicates the development prototype of the mobile application and accident detection system. The prototype of an accident detection system and car rental mobile application is currently designed by on all the simulation using Proteus as described in this work. The sensors, which are typically located in the car's dashboard, monitor for changes in impact. When an accident is detected, the software sends a notification to the driver's mobile phone. The notification includes the location of the accident, the severity of the accident, and any other relevant information.

## 5. CONCLUSION

The Internet of Things (IoT) and mobile app management provide a number of benefits when used to the automobile rental industry, including increased productivity, comfort, and security. Mobile apps simplify the rental process for customers [7] while IoT-enabled accident detection devices report incidents in real time to rental agencies [8]. Proteus 8 simulations validated the system design of the implemented hardware. Future work involves the development of a car rental service with the implementation of a car accident detection system. Real-time tracking utilizing IoT in car rental services facilitates better fleet management, improved customer service, increased efficiency, and cost savings.

## ACKNOWLEDGEMENT

The authors extend their gratitude to the Jabatan Kejuruteraan Elektronik, Fakulti Kejuruteraan Elektrik dan Elektronik, Universiti Tun Hussein Onn, Batu Pahat, Johor, Malaysia for their support in simulating this work using Proteus.

## REFERENCES

- [1] F. Y. H. Ahmed, E. B. Hazlan, and M. I. Abdulla, "Enhancement of Mobile-Based Application for Vehicle Rental," in 2021 IEEE 11th IEEE Symposium on Computer Applications & Industrial Electronics (ISCAIE), Penang, Malaysia: IEEE, Apr. 2021, pp. 163–168. doi: 10.1109/ISCAIE51753.2021.9431820.
- [2] B. B. Oliveira, M. A. Carravilla, and J. F. Oliveira, "Fleet and revenue management in car rental companies: A literature review and an integrated conceptual framework," *Omega*, vol. 71, pp. 11–26, Sep. 2017, doi: 10.1016/j.omega.2016.08.011.
- [3] A. Shaik et al., "Smart Car: An IoT Based Accident Detection System," in 2018 IEEE Global Conference on Internet of Things (GCIoT), Alexandria, Egypt: IEEE, Dec. 2018, pp. 1–5. doi: 10.1109/GCIoT.2018.8620131.
- [4] S. Kumar, P. Tiwari, and M. Zymbler, "Internet of Things is a revolutionary approach for future technology enhancement: a review," *J. Big Data*, vol. 6, no. 1, p. 111, Dec. 2019, doi: 10.1186/s40537-019-0268-2.
- [5] K. L. Narayanan, C. R. S. Ram, M. Subramanian, R. S. Krishnan, and Y. H. Robinson, "IoT based Smart Accident Detection & Insurance Claiming System," in 2021 Third International Conference on Intelligent Communication Technologies and Virtual Mobile Networks (ICICV), Tirunelveli, India: IEEE, Feb. 2021, pp. 306–311. doi: 10.1109/ICICV50876.2021.9388430.
- [6] S. Roy, A. Kumari, P. Roy, and R. Banerjee, "An Arduino Based Automatic Accident Detection and Location Communication System," in 2020 IEEE 1st International Conference for Convergence in Engineering (ICCE), Kolkata, India: IEEE, Sep. 2020, pp. 38–43. doi: 10.1109/ICCE50343.2020.9290701.
- [7] C. S. Mon, T. K. Tee, and A. 'Aatieff A. Hussin, "A Prototype of a Mobile Car Rental System," *J. Phys. Conf. Ser.*, vol. 1529, no. 3, p. 032023, Apr. 2020, doi: 10.1088/1742-6596/1529/3/032023.
- [8] A. H. Alquhali, M. Roslee, M. Y. Alias, and K. S. Mohamed, "IoT Based Real-Time Vehicle Tracking System," in 2019 IEEE Conference on Sustainable Utilization and Development in Engineering and Technologies (CSUDET), Penang, Malaysia: IEEE, Nov. 2019, pp. 265–270. doi: 10.1109/CSUDET47057.2019.9214633.
- [9] A. Thakur, "Car Rental System," *Int. J. Res. Appl. Sci. Eng. Technol.*, vol. 9, no. VII, pp. 402–412, Jul. 2021, doi: 10.22214/ijraset.2021.36339.
- [10] M. K. Priyan and G. U. Devi, "A survey on internet of vehicles: applications, technologies, challenges and opportunities".
- [11] S. Sakarin and G. Phanomchoeng, "The Development of Car Tracking System for Car Sharing Business by Using OBD-II Port," in 2021 International Symposium on Electrical, Electronics and Information Engineering, Seoul Republic of Korea: ACM, Feb. 2021, pp. 170–174. doi: 10.1145/3459104.3459134.
- [12] E. Turban, J. Whiteside, D. King, and J. Outland, "Mobile Commerce and the Internet of Things," in *Introduction to Electronic Commerce and Social Commerce*, in Springer Texts in Business and Economics. Cham: Springer International Publishing, 2017, pp. 167–199. doi: 10.1007/978-3-319-50091-1\_6.
- [13] K. Shaukat, T. M. Alam, I. A. Hameed, W. A. Khan, N. Abbas, and S. Luo, "A Review on Security Challenges in Internet of Things (IoT)," in 2021 26th International Conference on Automation and Computing (ICAC), Portsmouth, United Kingdom: IEEE, Sep. 2021, pp. 1–6. doi: 10.23919/ICAC50006.2021.9594183.
- [14] M. G. Albino and V. Acebedo, "Development of Car Rental Management System with Scheduling Algorithm," 2021.