



Optimizing Solar Power Generation for Residential Loads in Remote Regions of Indonesia

Agung Nugraha¹, Rico Armadan², and Taryo^{3*}

¹Dept. of Electrical Engineering, Faculty of Engineering, University of Swadaya Gunung Jati, Indonesia.

KEYWORDS

Solar Power Generation
Off-grid System
PVsyst
Residential House
Remote Area

ARTICLE HISTORY

Received 28 July 2024
Received in revised form
2 August 2024
Accepted 3 August 2024
Available online 9 August
2024

ABSTRACT

The increasing energy demand in Indonesia, driven by rapid technological advancements across various industries and a growing population, necessitates the exploration of alternative energy sources. The reliance on traditional Steam Power Plants has contributed to rising greenhouse gas emissions and increasing operational costs, prompting the need for cleaner and more sustainable energy solutions. Solar energy emerges as a promising alternative to address these challenges. This study focuses on developing a solar power generation system capable of meeting the electrical energy needs in isolated areas. Using the PVsyst application, a new renewable energy system was designed to cater to the electricity requirements of residential homes. The study findings indicate that the system can generate 13,683 watts of electrical energy using eight solar panels, each with a capacity of 330 Wp. Additionally, the system includes 15 batteries with a capacity of 250 Ah to store energy. The designed system successfully meets the daily electricity demand of 8,210 watts for residential homes. To maximize solar energy absorption, the optimal tilt angle for the solar panels was determined to be 7 degrees. This study demonstrates that solar power generation systems are a viable and effective alternative for fulfilling electrical energy needs in isolated areas, offering a sustainable solution to reduce greenhouse gas emissions and reliance on conventional power sources.

© 2024 The Authors. Published by Penteract Technology.

This is an open access article under the CC BY-NC 4.0 license (<https://creativecommons.org/licenses/by-nc/4.0/>).

1. INTRODUCTION

Indonesia has significant potential to adopt solar panels as a future energy source due to its equatorial location, which allows almost all regions of the country to receive consistent and optimal sunlight throughout the year [1]. The growing energy demand, driven by rapid technological advancements and population growth, is becoming increasingly urgent [2]. As the country progresses in science, technology, and infrastructure development, the need for electrical energy continues to rise [3]. Indonesia has committed to reducing greenhouse gas (GHG) emissions by 29% compared to Business as Usual (BAU) by 2030, with an additional reduction of up to 41% possible with international assistance [4][5]. In this context, alternative energy sources, particularly solar energy, are critical to achieving these targets while also reducing reliance on conventional power sources.

This research aims to design and implement an off-grid solar power system for residential homes in remote areas [6], addressing the need for reliable and cost-effective energy

solutions that are independent of the state electricity company's grid [7]. Solar power is increasingly favored for its abundance, sustainability, and minimal environmental impact, making it an ideal candidate for such applications [8-9].

Solar energy is harnessed through solar panels that operate based on the photovoltaic effect, using solar cells made of single crystalline silicon [12]. The Majalengka Regency Statistics Agency reports that more than 4,000 residential houses in the region lack access to electricity [10]. This research will explore the potential of solar energy to power these isolated homes, which are disconnected from the national electricity grid [11].

While solar energy has been utilized for power generation for many years, its application has largely been limited to small-scale systems [12][13]. To optimize the implementation of solar power plants, several factors must be considered, including climate, humidity, temperature, and the positioning of solar cells [14]. Additionally, an uneven power grid system can lead

*Corresponding author:

E-mail address: Corresponding author <taryo@ugj.ac.id>.

<https://doi.org/10.56532/mjsat.v4i3.355>

2785-8901/ © 2024 The Authors. Published by Penteract Technology.

This is an open access article under the CC BY-NC 4.0 license (<https://creativecommons.org/licenses/by-nc/4.0/>).

to supply shortages, particularly in small industries and remote areas [15].

The increasing demand for sustainable energy solutions has led to a growing interest in solar power generation, particularly in remote areas. Research indicates that utilizing solar energy can significantly mitigate reliance on traditional power sources and help achieve greenhouse gas reduction targets. For instance, Khan et al. (2016) provided valuable energy audit data for resort islands in the South China Sea, highlighting the importance of renewable energy assessments in identifying viable solutions for energy supply [17][18]. Furthermore, the integration of machine learning algorithms for forecasting solar irradiation and temperature can enhance the efficiency of solar power systems, as demonstrated by Zahraoui et al. (2022) [19]. Additionally, the performance evaluation of solar PV inverter controls has been shown to effectively mitigate overvoltage issues in medium voltage distribution networks, as noted by Almeida et al. (2021) [20]. The optimal placement and sizing of distributed generation systems are also crucial for maximizing the benefits of renewable energy integration, as emphasized by Seet et al. (2019) [21]. Collectively, these studies underscore the potential of solar power as a reliable energy source that can contribute to the sustainability goals of isolated communities.

This study will assess these challenges and the overall feasibility of solar power as a sustainable energy solution for isolated communities in Majalengka Regency.

2. METHODOLOGY

This study employs an experimental quantitative method, focusing on the development of solar power plants through a systematic design process. The research flow is shown in Figure 1. The experimental research design includes a treatment group based on simulation results, structured as follows:

2.1 Location and Time

The research will be conducted over a one-month period, from April to May 2024. The analysis will take place in Mekarmulya Village, Kertajati Sub-District, Majalengka District, West Java Province, Indonesia. The location is illustrated in the Figure 2.

2.2 Tools

PVsyst, a simulation software, will be utilized to assess the performance and operation of solar power generation systems. This tool enables the evaluation of different system configurations while simultaneously calculating the energy produced. The simulation results are based on a recreated measurement system that considers the geographical characteristics of the solar panel installation site. The outcomes can be presented in hourly, daily, monthly, and yearly formats [17].

2.3 Residential load

To design the solar power plant effectively, data on residential electrical loads is essential for calculating daily electricity consumption. The data presented in Table 1.

2.4 Design

a. Residential Electrical Installation Design

The solar power plant design includes a residential house measuring 9 meters in length and 7 meters in width, located in

Mekarmulya Village, Kertajati Sub-District, Majalengka District, West Java, Indonesia. The architectural layout of the house is depicted in Figure 3.

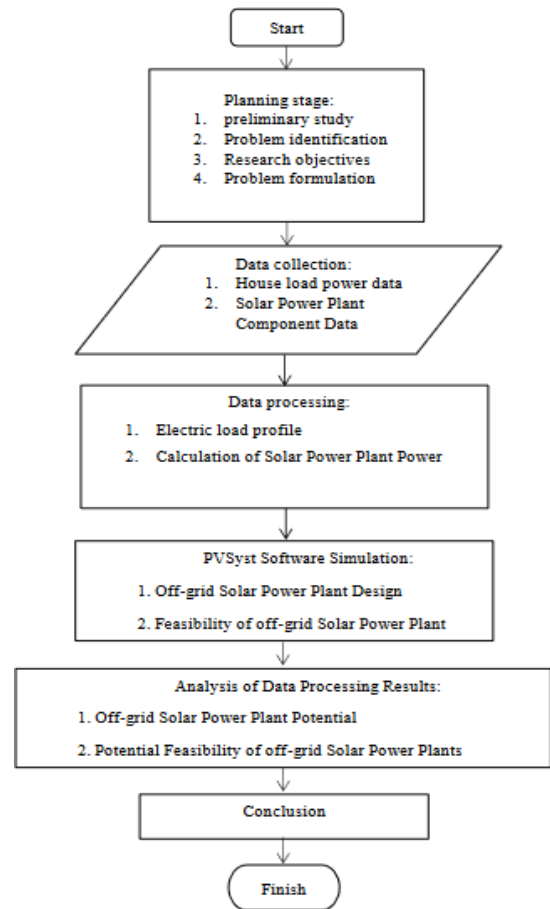

Fig. 1. Flowchart

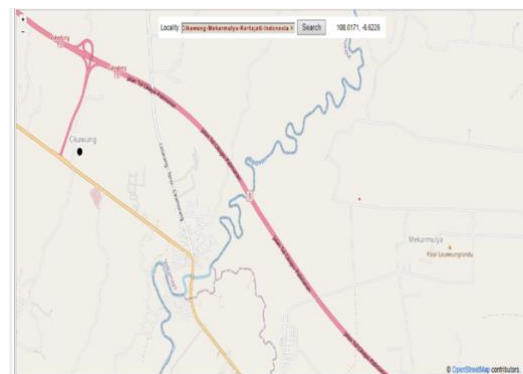

Fig. 2. Location of Research

b. Design of solar panel circuit

The design of the solar PV system incorporates several essential components, including:

- Solar Panels: These convert sunlight into electricity.
- Batteries: These store the generated energy for use during periods without sunlight.
- DC to AC Inverter: This device converts direct current (DC) from the solar panels and batteries into alternating current (AC) for residential use.

- Solar Charge Controller (SCC): This component regulates the voltage and current coming from the solar panels to the batteries, preventing overcharging and ensuring optimal battery performance.
- KWH Meter: This measures the amount of energy consumed by the household.
- Load: The electrical devices and appliances that will utilize the generated power.

Together, these components form a complete solar panel circuit designed to efficiently generate, store, and distribute solar energy for residential use.

Table 1. Load demand data

No	Appliances	Power	Quantity
1.	Lamps LED Philips	10 watt	8
2.	Miyako Rice Cooker 1.8 Liter	200 watt	1
3.	Sharp Washing Machine 2 tube 7 Kg	150 watt	1
4.	Sharp 1-door refrigerator 166 Liters	90 watt	1
5.	Tv LG 43 Inc	75 watt	1
6.	AC 1 pk Sharp	740 watt	1

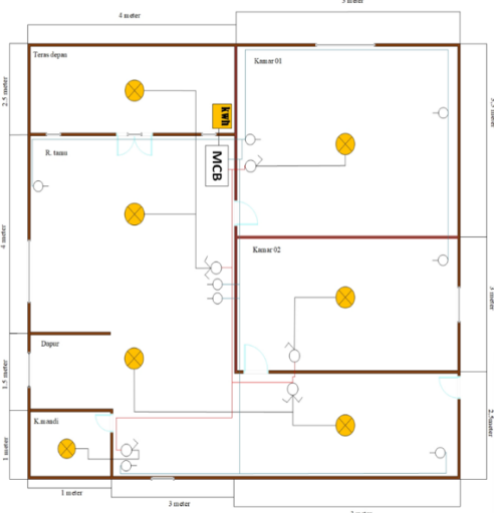

Fig. 3. Residential Electrical Installation Design

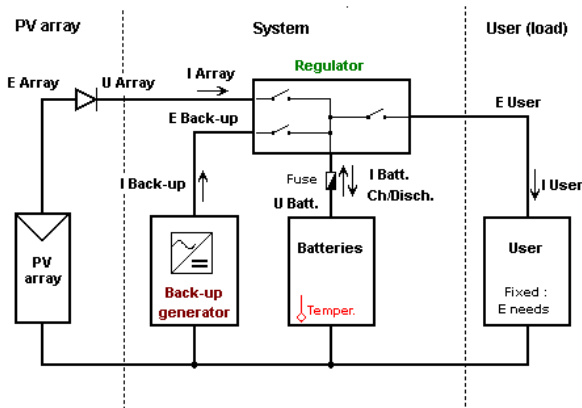

Fig. 4. Standalone PV system design

c. Residential Load

Refer to Table 1 for the calculations of the residential load current values utilized in the simulation procedure with PVsyst. These calculations enable researchers to establish a direct development design for a photovoltaic solar power plant. The calculations presented in the Table are based on the equation (1).

$$Wh = Ph \tag{1}$$

Description :

Wh = Discharging capacity

P = The load power used (Watt)

h = Length of load utilized (Hour)

Table 2. Estimated electric power demand from residential electricity loads power

Tool Name	Power	Total	Power-On Time (hour)	Total Power Consumption (Wh)
Lamp	10 watt	8	10	800
Tv	75 watt	1	6	450
Rice Cooker	200 watt	1	4	800
Washing machine	150 watt	1	2	300
Refrigerator	90 watt	1	24	2160
Ac 1 pk	740 watt	1	5	3700
Totally power consumption / day				8,210

It is important to note that in a photovoltaic solar power plant, not all of the generated electricity is available for consumption. Approximately 40% of the electric energy is lost when the solar module delivers power to the household consumer due to various factors, including electronic inefficiencies. Therefore, an additional 40% of power must be accounted for in the total power consumption. This can be calculated using the following formula:

$$Total\ Power = House\ Power / 0.60 \tag{1}$$

d. Solar PV Design

When calculating solar panels, use the following formula to determine the power capacity and number of solar panels used.

$$Solar\ Panels = Total\ Power / Optimal\ Sunlight\ Hours \tag{2}$$

$$Quantity\ of\ Solar\ Panels = Discharging\ Power / Solar\ Panel\ Power\ (Wp) \tag{3}$$

Where:

Discharging Power refers to the total power output needed from the solar panels.

Solar Panel Power (Wp) is the rated output power of a single solar panel in watts peak.

e. Battery Design

The battery is charged for both daytime and nighttime use. However, when operating the inverter, it is important to note that not 100% of the battery's electrical energy is accessible due to potential energy losses, which can be as high as 5%. Consequently, a 5% reserve must be added to account for this loss. The equation is as follows:

$$\text{Battery Capacity} = \text{Home Power} / 0.95 \quad (4)$$

f. Inverter design

To determine the appropriate inverter size, we start with the daily load requirement. Based on the previous data, the load used in one day is 1,265 Watts. Therefore, it is necessary to select an inverter with an output capacity greater than 1,265 Watts to ensure adequate power supply.

g. Solar Charger Controller

In calculating the Solar Charge Controller (SCC), we begin by examining the specifications of the solar panel used to determine the output power of the SCC. For this study, we will consider the specifications of a 330 Wp polycrystalline solar panel.

- Maximum Power (P_{\max}) 330 Watt Peak.
- Voltage at Pmax (V_{mp}) 77 V
- Current At Pmax (I_{mp}) 35 A
- Open Circuit Voltage (V_{oc}) 103 V
- Short Circuit Current (I_{sc}) 37,9 A

To calculate the Solar Charge Controller (SCC), the following equation is used:

$$\text{SCC Power} = I_{sc} \times \text{Number of solar panels} \quad (5)$$

Where:

I_{sc} is the short-circuit current of a single solar panel (measured in amperes).

Number of Solar Panels refers to the total count of solar panels in the system.

3. RESULT AND DISCUSSIONS

The simulation results generated using PVsyst provide the analyst with precise data for comparison. By ensuring the accuracy of these values, the design and planning of solar power installations become significantly more efficient. This accuracy not only aids in optimizing the performance of solar power plants but also streamlines the overall development process, enabling the creation of effective and reliable solar energy systems with greater ease.

3.1 Tilt and azimuth

The tilt angle of the solar panel used in the simulation is set at 70 degrees to optimize solar energy retention. This tilt is calculated based on the southern latitude (LS) coordinate, as illustrated in the Figure 5.

3.2 PV Array

The design of the solar power plant for residential houses will incorporate eight (8) units of Eldora VSP.72.330.05_U polycrystalline solar panels. Each panel has a power capacity of 330 Wp (Watt Peak) and a voltage of 32 volts, resulting in a total output power of 2,640 Wp. This configuration is illustrated in the following figure.

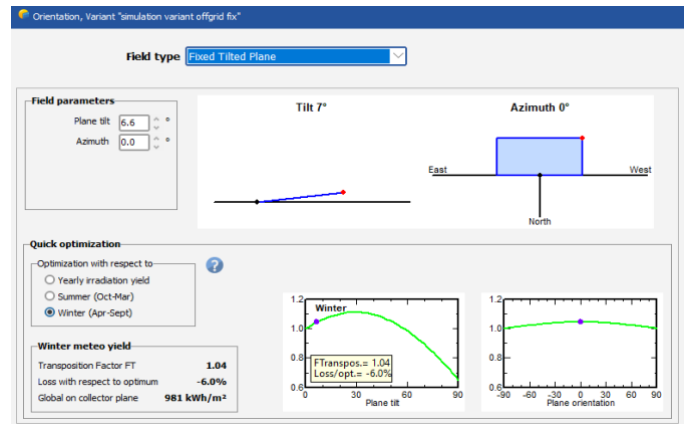

Fig. 5. Determining the tilt angle of solar panels

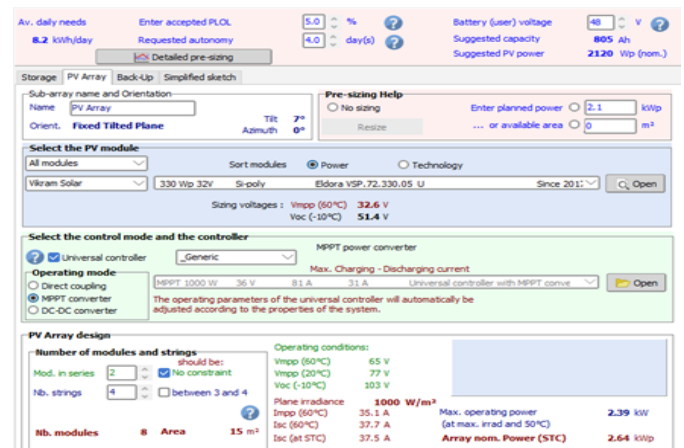

Fig. 6. Specifications of Solar Panels

3.3 Battery

In the simulation, a total of fifteen (15) MPG 12V 50 F batteries will be utilized to support household power needs during nighttime and cloudy weather conditions. Each battery has a capacity of 250 Ah, providing a stored energy of 7.2 kWh. The total energy capacity of the entire battery bank amounts to 8,235 kWh. Figure 7 displays the specifications of the batteries.

3.4 Off Grid Solar PV System Simulation Results

The simulation results from PVsyst indicate a total household load of 8,210 Wh. The design of the solar power plant generates a simulated output of 2,640 Wp, with an average daily power production of 8.2 kWh. The following simulation results are illustrated in the figure below.

In Figure 8, the simulation results of the Solar Power Plant are represented graphically as follows:

- The blue color represents the output power when the battery is fully charged, producing 1.15 kWh/kWp in one day.
- The purple color indicates the energy lost in the solar panel, amounting to 0.83 kWh/kWp.
- The green color reflects the charging system loss in the battery, reaching 0.25 kWh/kWp in one day.
- The red color illustrates the electric energy consumed by household load power, totaling 3 kWh/kWp in one day.

Av. daily needs 8.2 kWh/day Enter accepted PLOL 5.0 % Requested autonomy 4.0 day(s) Battery (user) voltage 48 V Suggested capacity 805 Ah Suggested PV power 2112 Wp (nom.)

Storage PV Array Back-Up Simplified sketch

Procedure
The Pre-sizing suggestions are based on the Monthly meteo and the user's needs definition

1. - Pre-sizing Define the desired Pre-sizing conditions (PLOL, Autonomy, Battery voltage)
2. - Storage Define the battery pack (default checkboxes will approach the pre-sizing)
3. - PV Array design Design the PV array (PV module) and the control mode. You are advised to begin with a universal controller.
4. - Back-Up Define an eventual Genset

Specify the Battery set

Sort batteries by voltage capacity manufacturer

Narada 12 V 50 Ah Pb Sealed Gel MPG 12V 50 F Since 2018

Lead-acid

batteries in series Number of batteries 15 Battery pack voltage 36 V
 batteries in parallel Number of elements 90 Global capacity 250 Ah
 100.0 % Initial State of Wear (nb. of cycles) Nb. cycles at 80% DOD 1000 Stored energy (80% DOD) 7.2 kWh
 100.0 % Initial State of Wear (static) Total stored energy during the battery life 8235 kWh

Fig. 7. Battery specification

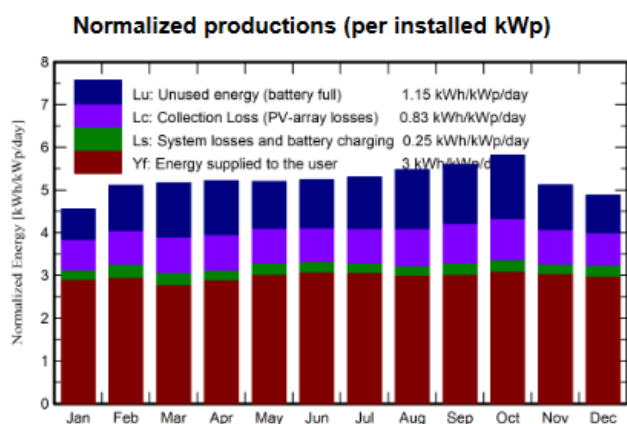

Fig. 8. Power output of the PV System

4. CONCLUSION

According to the power calculations, the daily electrical load requires 8,210 Watts of power. Simulations with PVSyst using Eldora VSP.72.330.05_U Polycrystalline solar panels with batteries for storing electrical energy with MPG 12V 50 F type demonstrate the electrical power generated by off-grid solar power plants of 13,683 Watt. The system consists of 8 solar panels, each with a capacity of 330 Wp, and 15 batteries, each with a capacity of 250 Ah. The system controller can manage a total of 8,235 kWh. To optimize solar energy absorption, the solar panels' tilt angle is set to 7 degrees..

REFERENCES

- [1] Yunus Shiddiq And Anrizal Akbar Alif, "PVSYST-Based Solar Power Plant Planning," PVSYST-Based Solar Power Plant Planning, Vol. 9, Pp. 88–92, 2022, Doi: 10.31963/Intek.
- [2] Suriadi And Syukri Mahdi, "167-319-1-SM," Perencanaan Pembangkit Listrik Tenaga Surya Terpadu Menggunakan Software PVSYST Pada Komplek Perumahan, Vol. 9, Pp. 77–80, 2010.
- [3] R. Syahputra, D. Mundakir, Y. Ardiyanto, K. Purwanto, And A. Jamal, "Design Of A Household-Scale Solar Power Plant Using PVSYST Software," AIP Conf Proc, Vol. 2499, No. 03002, Pp. 1–6, Nov. 2022, Doi: 10.1063/5.0105975.
- [4] B. Winardi, E. W. Sinuraya, A. Nugroho, And E. Dolphina, "Design Of Hybrid Solar Power Plant For Household Electricity Loads 1300 VA," International Journal Of Basic And Applied Science, Vol. 10, No. 4, Pp. 117–125, 2022, [Online]. Available: WwW.Ijobas.Pelnus.Ac.Id

- [5] I. Nusantara, N. R. Alham, H. Nugroho, Muslimin, And R. M. Utomo, "Design For Application Of Solar Power Plant In The Faculty Of Engineering Mulawarman University," Design For Application Of Solar Power Plant In The Faculty Of Engineering Mulawarman University, Pp. 64–79, 2023, Doi: 10.2991/978-94-6463-180-7_10.
- [6] M. Bernandos, A. F. Perangin Angin, And F. S. Pratama, "Designing An On-Grid Solar Power Plant At The Women's Dormitory Building Of Aviation Polytechnic Jayapura," Jurnal Dinamika Vokasional Teknik Mesin, Vol. 8, No. 2, Pp. 125–134, Oct. 2023, Doi: 10.21831/Dinamika.V8i2.67281.
- [7] U. S. Muhammad And B. Purwahyudi, "Design Of Solar Power Plant For Electricity Source Of The Drying Machine," JEECS (Journal Of Electrical Engineering And Computer Sciences), Vol. 6, No. 2, Pp. 1081–1086, Dec. 2021, Doi: 10.54732/JeeCS.V6i2.202.
- [8] A. Gifson, M. Rt Siregar, And M. P. Pambudi, "Rancang Bangun Pembangkit Listrik Tenaga Surya (Plts) On Grid Di Ecopark Ancol," Sekolah Tinggi Teknik Pln, Vol. 22, No. 1, Pp. 23–33, 2020.
- [9] M. Dwi Et Al., "JUPITER (Jurnal Pendidikan Teknik Elektro) Perancangan Pembangkit Listrik Tenaga Surya (PLTS) Pada Kolam Budidaya Di Daerah Sentono Menggunakan Software Pvsyst," Design Of Solar Power Plant (PLTS) On Aquaculture Ponds In Sentono Area Using Pvsyst Software, Vol. 06, Pp. 18–30, 2021.
- [10] R. Rahman, P. Teknik Elektro, I. Kalimantan, And M. Banjarmasin, "Analisis Perencanaan Pembangkit Listrik Tenaga Surya Offgrid Untuk Rumah Tinggal Di Kota Banjarbaru," 2021. [Online]. Available: <https://Ojs.Uniska-Bjm.Ac.Id/Index.Php/Eieit>
- [11] H. Al-Zoubi, Y. Al-Khasawneh, And W. Omar, "Design And Feasibility Study Of An On-Grid Photovoltaic System For Green Electrification Of Hotels: A Case Study Of Cedars Hotel In Jordan," International Journal Of Energy And Environmental Engineering, Vol. 12, No. 4, Pp. 611–626, Dec. 2021, Doi: 10.1007/S40095-021-00406-Z.
- [12] M. Nuruddin, A. Fahriannur, S. Anwar, And R. I. Widya, "Design Of The Off-Grid Solar Power Plant Installation System For Cooking Process Using Electric Stove," The Second International Conference On Food And Agriculture, Pp. 578–583.
- [13] B. Harianto And M. Karjadi, "Planning Of Photovoltaic (PV) Type Solar Power Plant As An Alternative Energy Of The Future In Indonesia," ENDLESS: International Journal Of Future Studies, Vol. 5, No. 2, Pp. 182–195, 2022, [Online]. Available: <https://Endless-Journal.Com/Index.Php/Endless/>
- [14] M. B. Arief, M. Widyartono, W. Aribowo, And A. L. Wardani, "Desain Pembangkit Listrik Tenaga Surya Off-Grid Dan Monitoring Berbasis Node-Red," Elposys: Jurnal Sistem Kelistrikan, Vol. 11, No. 1, Pp. 2–6, 2024.
- [15] A. Gilang Mahesa, K. Hie Khwee, J. Teknik Elektro, F. Teknik, And U. H. Tanjungpura Jalan Hadari Nawawi, "Studi Perencanaan Pembangkit Listrik Tenaga Surya Sistem Hybrid Sebagai Sumber Energi Alternatif," Studi Perencanaan Pembangkit Listrik Tenaga Surya Sistem Hybrid Sebagai Sumber Energi Alternatif, 2021.
- [16] M. Siregar, C. Hashiholan Pardosi, K. Octavianus Bachri, T. Nur, And L. W. Pandjaitan, "Comparison Of Actual Results And Pvsyst Simulation In The Design Of Off-Grid Solar Power Generation System (PLTS) In Karuni Village, Southwest Sumba," Jurnal Elektro, Vol. 17, No. 1, Pp. 1–12, 2024, [Online]. Available: <https://Ejournal.Atmajaya.Ac.Id/Index.Php/JTE>
- [17] Khan, M. R. B., Jidin, R., & Pasupuleti, J. (2016). Energy audit data for a resort island in the South China Sea. Data in brief, 6, 489-491. <https://doi.org/10.1016/j.dib.2015.12.033>
- [18] Khan, M. R. B., Jidin, R., & Pasupuleti, J. (2016). Data from renewable energy assessments for resort islands in the South China Sea. Data in brief, 6, 117-120. <https://doi.org/10.1016/j.dib.2015.11.043>
- [19] Zahraoui, Y., Alhamrouni, I., Mekhilef, S. and Khan, M.R.B., 2022. Machine learning algorithms used for short-term PV solar irradiation and temperature forecasting at microgrid. In Applications of AI and IOT in Renewable Energy (pp. 1-17). Academic Press <https://doi.org/10.1016/B978-0-323-91699-8.00001-2>
- [20] Almeida, D., Pasupuleti, J., Raveendran, S. K., & Basir Khan, M. R. (2021). Performance evaluation of solar PV inverter controls for overvoltage mitigation in MV distribution networks. Electronics, 10(12), 1456. <https://doi.org/10.3390/electronics10121456>

- [21] Seet, C. C., Pasupuleti, J., & Khan, M. R. B. (2019). Optimal placement and sizing of distributed generation in distribution system using analytical method. *International Journal of Recent Technology and Engineering*, 8(4), 6357-6363. <https://doi.org/10.35940/ijrte.D5120.118419>
- [22] S. A. D. Mohammadi And C. Gezezin, "Design And Simulation Of Grid-Connected Solar PV System Using PVSYST, PVGIS And HOMER Software," *International Journal Of Pioneering Technology And Engineering*, Vol. 1, No. 01, Pp. 36-41, Jun. 2022, Doi: 10.56158/Jpte.2022.24.1.01